



Features

- Compliant with SFF-8431 SFP+ MSA
- Compliant with IEEE802.3ae 10G BASE-SW/SR
- 850nm VCSEL transmitter
- PIN photo-detector
- 2-wire interface for management specifications compliant with SFF 8472 digital diagnostic monitoring interface for optical transceivers
- All-metal housing for superior EMI performance
- Low power consumption
- Advanced firmware allow customer system encryption information to be stored in transceiver
- Cost effective SFP+ solution, enables higher port densities and greater bandwidth
- RoHS Compliant

Applications

- High-speed storage area networks
- Computer cluster cross-connect
- Custom high-speed data pipes
- Inter Rack Connection

Absolute Maximum Ratings

Parameter	Symbol	Min.	Max.	Units	Note
Storage Temperature	T_c	-40	85	°C	
Operating Case Temperature	T_c	0	70	°C	
Supply Voltage	V_{cc}	0	3.6	V	
Relative Humidity	RH	5	95	%	
RX Input Average Power	P_{max}	---	1.5	dBm	

Recommended Operating Conditions

Parameter	Symbol	Min.	Max.	Units	Note
Case Operating Temperature	T_c	0	70	°C	
Supply Voltage	V_{cc}	3.135	3.465	V	
Supply Current	I_{cc}	---	250	mA	
Power Consumption		---	800	mW	

Link Distances

<i>Parameter</i>	<i>Fiber Type</i>	<i>Modal Bandwidth @ 850nm (MHz-km)</i>	<i>Distance Range (m)</i>
10.3 GBd	62.5/125 μ m MMF	160	2-26
	62.5/125 μ m MMF	200 (OM1)	2-33
	50/125 μ m MMF	400	2-66
	50/125 μ m MMF	500 (OM2)	2-82
	50/125 μ m MMF	2000 (OM3)	2-300

Diagnostics

<i>Parameter</i>	<i>Symbol</i>	<i>Accuracy</i>	<i>Unit</i>	<i>Notes</i>
Temperature	Temp	± 3	$^{\circ}$ C	Over operating Temp
Voltage	VCC	± 0.08	V	Full operating range
Bias Current	Bias	± 10	mA	
TX Power	TX	± 3 dB	dBm	
RX Power	RX	± 3 dB	dBm	-1dBm to -12dBm range

Transmitter Electro-optical Characteristics

V_{CC} = 3.135 V to 3.465 V, T_C = 0 °C to 70 °C

<i>Parameter</i>	<i>Symbol</i>	<i>Min.</i>	<i>Typ.</i>	<i>Max.</i>	<i>Units</i>	<i>Note</i>
Data Rate		---	10.3125	---	Gbps	
Output Optical Power	<i>P_{out}</i>	-6.5	---	-1	dBm	
Center Wavelength	<i>λ_C</i>	840	850	860	nm	
Spectral Width (RMS)	<i>P_m</i>	---	---	0.45	nm	2
Relative Intensity Noise	<i>RIN</i>	---	---	-128	dB/Hz	12dB reflection
Optical Power OMA	<i>P_{oma}</i>	---	-1.5		dBm	1
Laser Off Power	<i>P_{OFF}</i>	---	---	-30	dBm	
Extinction Ratio	<i>ER</i>	3.5	---	---	dB	
Transmitter Dispersion Penalty	<i>TDP</i>	---	---	3.9	dB	
Optical Return Loss Tolerance		---	---	12	dB	
Single Ended Output Voltage Tolerance		-0.3	---	4	V	
C common mode voltage tolerance		15	---	---	mV	
TX Input Diff Voltage	<i>V_I</i>	180		700	mV	
TX Fault	<i>V_{oL}</i>	-0.3		0.4	V	At 0.7mA
Data Dependent Input Jitter	<i>DDJ</i>			0.1	UI	
Data Input Total Jitter	<i>TJ</i>			0.28	UI	

Note 1: per Tradeoff table 52.8, IEEE 802.3ae 2005

Note 2: Trade-offs are available between spectral width, center wavelength and minimum OMA, as shown in table 1

Table 1: Minimum 10GBASE-SR OMA as a Function of Wavelength and Spectral Width

Center Wavelength (nm)	RMS Spectral width (nm)								
	Up to 0.05	0.05 to 0.1	0.1 to 0.15	0.15 to 0.2	0.2 to 0.25	0.25 to 0.3	0.3 to 0.35	0.35 to 0.4	0.4 to 0.45
840 to 842	-4.2	-4.2	-4.1	-4.1	-3.9	-3.8	-3.5	-3.2	-2.8
842 to 844	-4.2	-4.2	-4.2	-4.1	-3.9	-3.8	-3.6	-3.3	-2.9
844 to 846	-4.2	-4.2	-4.2	-4.1	-4	-3.8	-3.6	-3.3	-2.9
846 to 848	-4.3	-4.2	-4.2	-4.1	-4	-3.8	-3.6	-3.3	-2.9
848 to 850	-4.3	-4.2	-4.2	-4.1	-4	-3.8	-3.6	-3.3	-3
850 to 852	-4.3	-4.2	-4.2	-4.1	-4	-3.8	-3.6	-3.4	-3
852 to 854	-4.3	-4.2	-4.2	-4.1	-4	-3.9	-3.7	-3.4	-3.1
854 to 856	-4.3	-4.3	-4.2	-4.1	-4	-3.9	-3.7	-3.4	-3.1
856 to 858	-4.3	-4.3	-4.2	-4.1	-4	-3.9	-3.7	-3.5	-3.1
858 to 860	-4.3	-4.3	-4.2	-4.2	-4.1	-3.9	-3.7	-3.5	-3.2

Receiver Electro-optical Characteristics

V_{CC} = 3.135 V to 3.465 V, T_C = 0 °C to 70 °C

Parameter	Symbol	Min.	Typ.	Max.	Units	Note
Receiver Sensitivity (OMA)	P_{sens}	---	---	-11.1	dBm	
Stressed Sensitivity (OMA)		---	---	-7.5	dBm	
Operating Center Wavelength	λ_C	840	850	860	nm	
Overload	P_{IN}	---	---	-1	dBm	
Receiver Reflectance		---	---	-12	dB	
Loss of Signal-Asserted	P_A	-30	---	---	dBm	
Loss of Signal-Deasserted	P_D	---	---	-12	dBm	
Loss of Signal-Hysteresis	P_H	0.5	---	---	dB	
Single Ended Output Voltage Tolerance		-0.3		4	V	
RX Output Diff Voltage	V_O	300		850	mV	
RX Output Rise and Fall Time	T_r/T_f	30			ps	20% to 80%
Total Jitter	T_J			0.7	UI	
Deterministic Jitter	D_J			0.42	UI	

Block Diagram of Transceiver

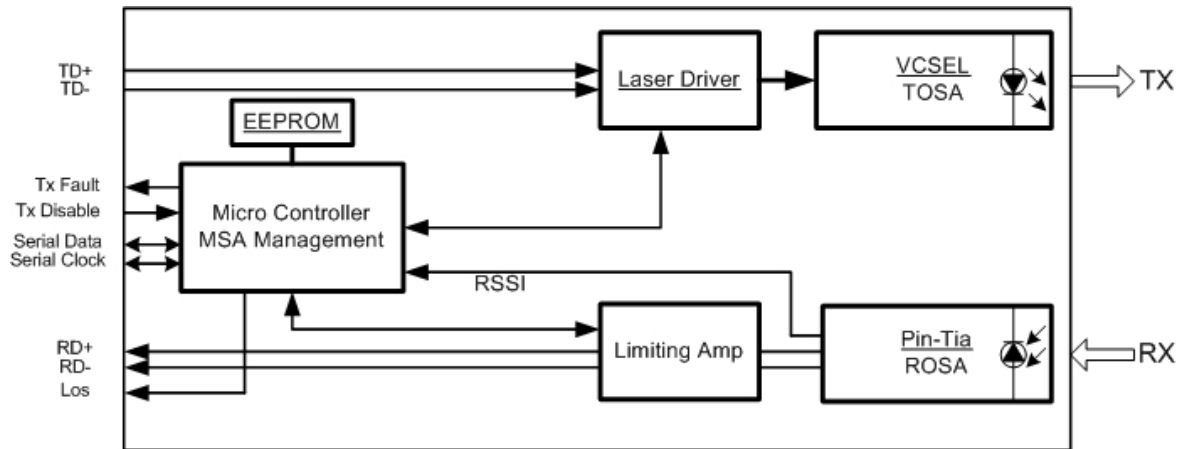

The SFP+ SR module electrical interface is compliant to SFI electrical specifications. The transmitter input and receiver output impedance is 100 Ohms differential. Data lines are internally AC coupled. The module provides differential termination and reduce differential to common mode conversion for quality signal termination and low EMI. SFI typically operates over 200 mm of improved FR4 material or up to about 150mm of standard FR4 with one connector.

The transmitter converts 10Gbit/s serial PECL or CML electrical data into serial optical data compliant with the 10GBASE-SR standard. An open collector compatible Transmit Disable (Tx_Dis) is provided. A logic "1," or no connection on this pin will disable the laser from transmitting. A logic "0" on this pin provides normal operation. The transmitter has an internal automatic power control loop (APC) to ensure constant optical power output across supply voltage and temperature variations. An open collector compatible Transmit Fault (TFault) is provided. TX_Fault is a module output contact that when high, indicates that the module transmitter has detected a fault condition related to laser operation or safety. The TX_Fault output contact is an open drain/collector and shall be pulled up to the Vcc_Host in the host with a resistor in the range 4.7-10 kΩ. TX_Disable is a module input contact. When TX_Disable is asserted high or left open, the SFP+ module transmitter output shall be turned off. This contact shall be pulled up to VccT with a 4.7 kΩ to 10 kΩ resistor

The receiver converts 10Gbit/s serial optical data into serial PECL/CML electrical data. An open collector compatible Loss of Signal is provided. Rx_LOS when high indicates an optical signal level below that specified in the relevant standard. The Rx_LOS contact is an open drain/collector output and shall be pulled up to Vcc_Host in the host with a resistor in the range 4.7-10 kΩ, or with an active termination. Power supply filtering is recommended for both the transmitter and receiver. The Rx_LOS signal is intended as a preliminary indication to the system in which the SFP+ is installed that the received signal strength is below the specified range. Such an indication typically points to non-installed cables, broken cables, or a disabled, failing or a powered off transmitter at the far end of the cable.

Pin Assignment

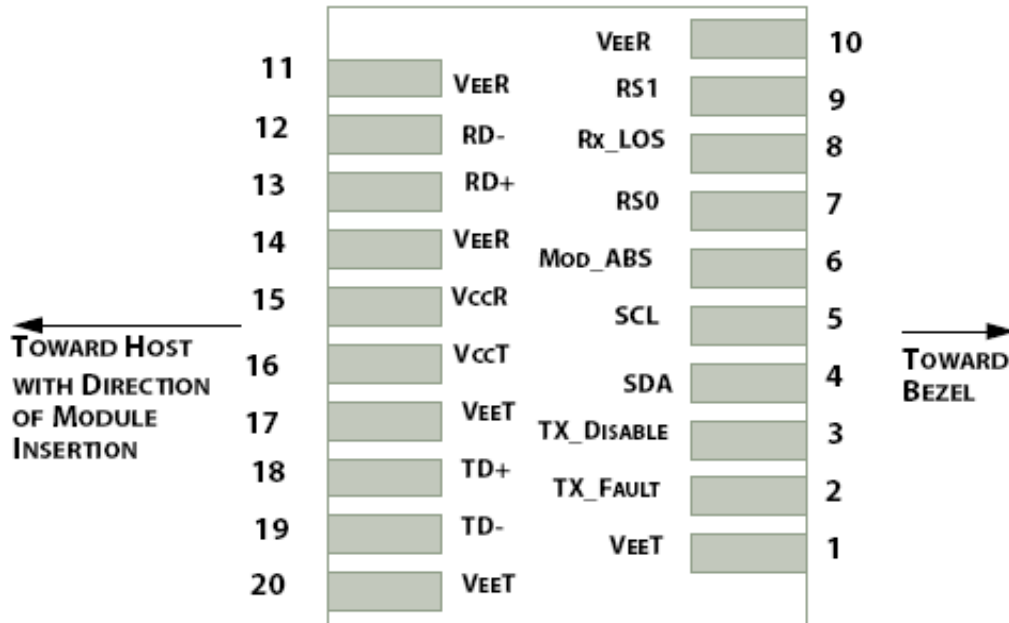

Module Interface to Host

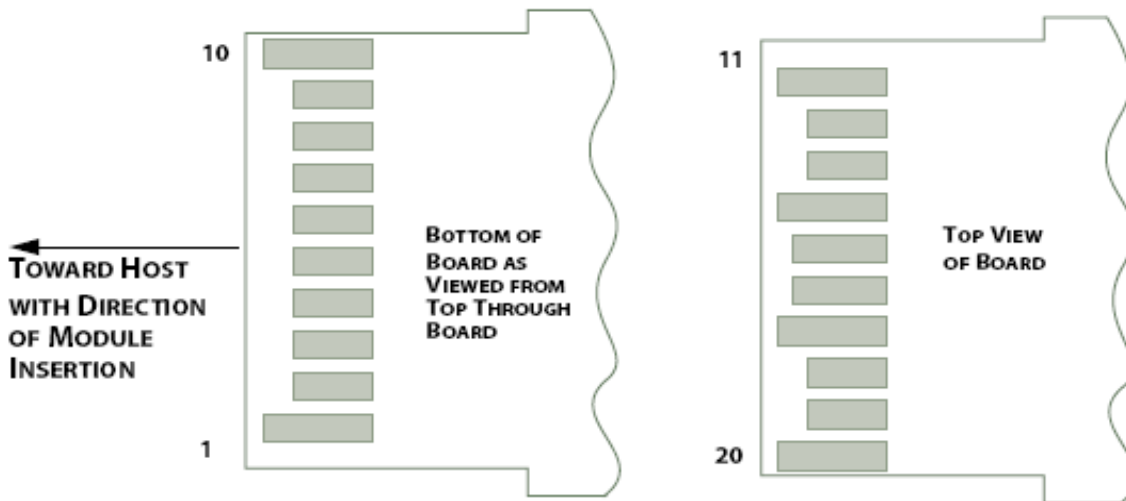

Module Contact Assignment

Pin Descriptions

<i>PIN</i>	<i>Logic</i>	<i>Symbol</i>	<i>Name / Description</i>	<i>Note</i>
1		VeeT	Module Transmitter Ground	1
2	LVTTL-O	TX_Fault	Module Transmitter Fault	
3	LVTTL-I	TX_Dis	Transmitter Disable; Turns off transmitter laser output	
4	LVTTL-I/O	SDA	2-Wire Serial Interface Data Line	2
5	LVTTL-I	SCL	2-Wire Serial Interface Clock	2
6		MOD_DEF0	Module Definition, Grounded in the module	
7	LVTTL-I	RS0	Not used	
8	LVTTL-O	RX_LOS	Receiver Loss of Signal Indication Active High	
9	LVTTL-I	RS1	Not used	
10		VeeR	Module Receiver Ground	1
11		VeeR	Module Receiver Ground	1
12	CML-O	RD-	Receiver Inverted Data Output	
13	CML-O	RD+	Receiver Data Output	
14		VeeR	Module Receiver Ground	1
15		VccR	Module Receiver 3.3 V Supply	
16		VccT	Module Receiver 3.3 V Supply	
17		VeeT	Module Transmitter Ground	1
18	CML-I	TD+	Transmitter Non-Inverted Data Input	
19	CML-I	TD-	Transmitter Inverted Data Input	
20		VeeT	Module Transmitter Ground	1

Note:

1. Module ground pins GND are isolated from the module case.
2. Shall be pulled up with 4.7K-10Kohms to a voltage between 3.15V and 3.45V on the host board.

Dimensions

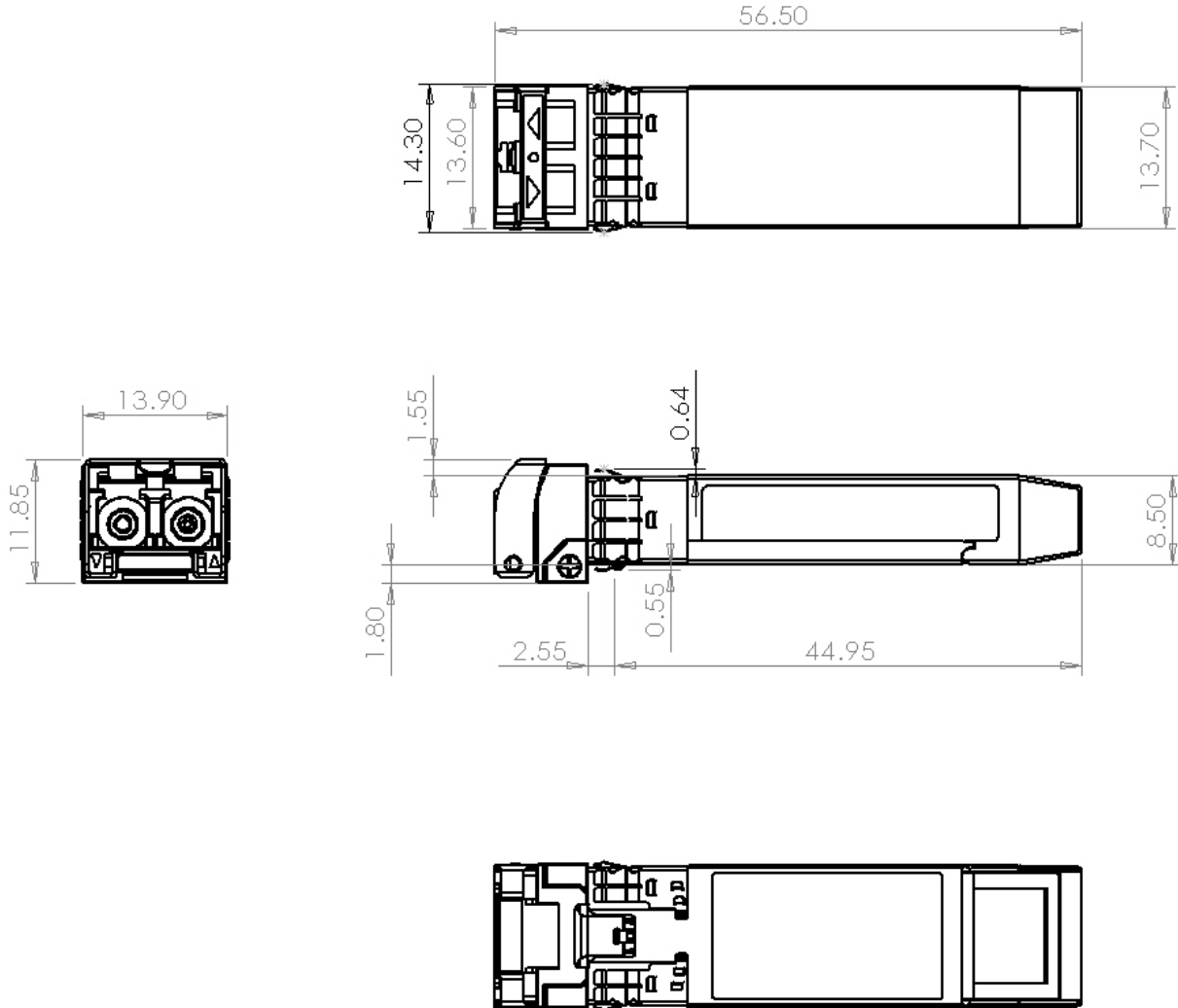

Optical Receptacle Cleaning Recommendations :

All fiber stubs inside the receptacle portions were cleaned before shipment. In the event of contamination of the optical ports, the recommended cleaning process is the use of forced nitrogen. If contamination is thought to have remained, the optical ports can be cleaned using a NTT international Cletop® stick type and HFE7100 cleaning fluid. Before the mating of patch-cord, the fiber end should be cleaned up by using Cletop® cleaning cassette.

Cleaning of patch-cord



Cleaning of fiber stub

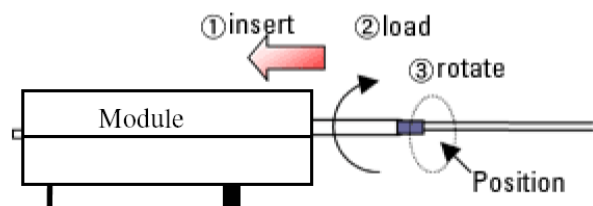

1. Insert
Ensure that stick is held straight when inserting into sleeve.
2. Load
Apply sufficient pressure (approx 600-700g) to ensure ferrule a little depressed in sleeve.
3. Rotate
Rotate stick clockwise 4-5 times, while ensuring direct contact with ferrule end-face is maintained.

*Notice: Number of possible wipes:
Maintenance (repair) ~1 use / piece
Equipment construction: 4 uses / piece (max.)*

Note: The pictures were extracted from NTT-ME website. And the Cletop® is a trademark registered by NTT-ME

Ordering Information

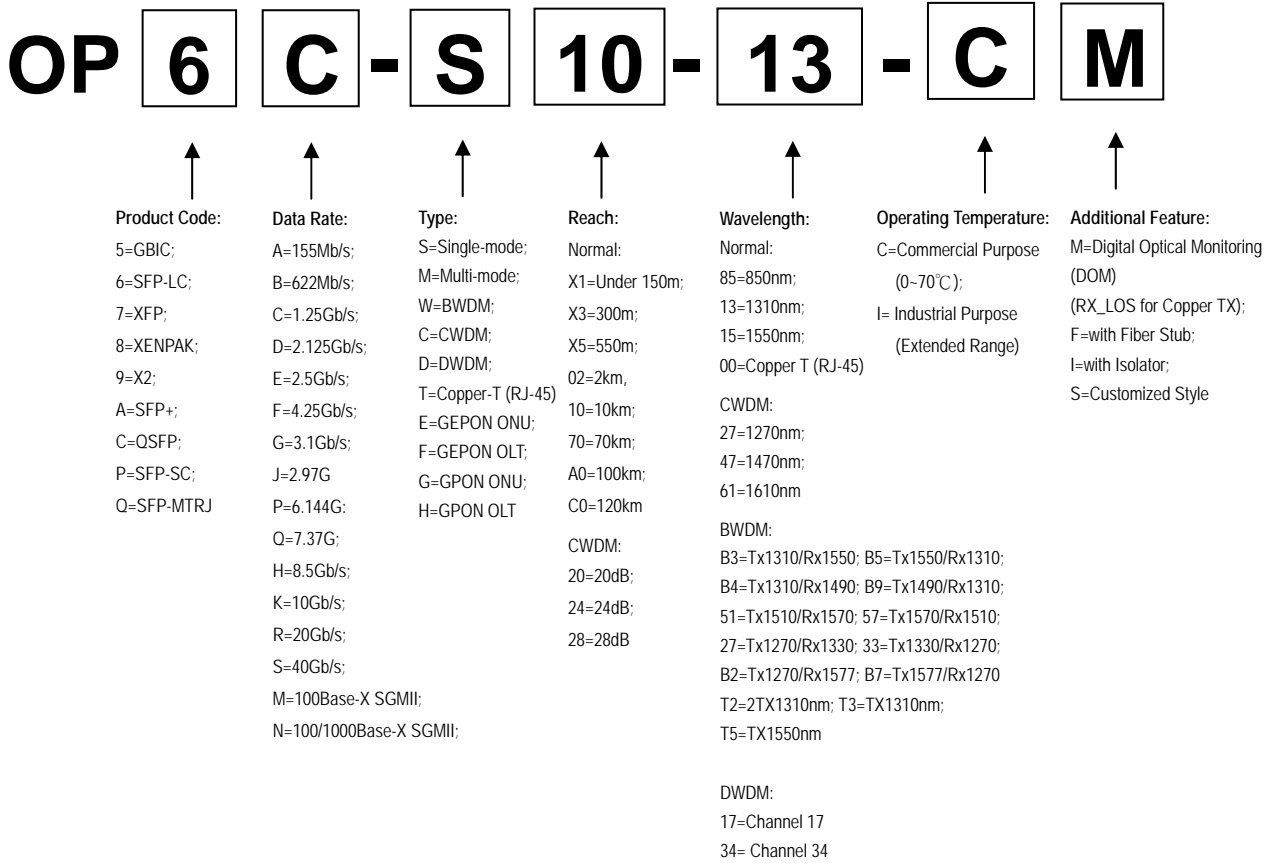

Model Number	Part Number	Reach	Input/Output	Signal Detect	Voltage	Temperature
SFP+10G-SR	OPAK-MX3-85-CB	300m	AC/AC	TTL	3.3V	0°C to 70 °C

Note: All information contained in this document is subject to change without notice.